

**DIRECTORATE OF LEGAL METROLOGY
FOOD SUPPLIES & CONSUMER WELFARE DEPARTMENT
KHANDAGIRI, ODISHA, BHUBANESWAR, PIN-751030**

TENDER NOTICE

(No.2/2020-21)

Sealed tenders through two bid systems are invited from the licence holders of Legal Metrology having work experience in fabrication under Central or State Government Departments for procurement of proving measures as detailed below by the Directorate of Legal Metrology, Odisha for construction of a calibration point for vehicle tanks in the Directorate Campus, Khandagiri, Bhubaneswar before 15th February-2021.

Sl.No.	Name of the Tender	Earnest money	Cost of tender form
1	Supply and installation of stainless steel proving measures 2000litres, 1000 litres, 500 litres, 100 litres (each one) along with fittings/accessories.	Rs.50,000/-	Rs.100/-

The bidders may download the tender documents with detailed technical specification and other terms and conditions from the DLM Portal <https://dln.pdsodisha.gov.in> or www.foododisha.in.

Controller Legal Metrology, Odisha
05.02.21

Standard Bidding Documents

Annexure-I

DIRECTORATE OF LEGAL METROLOGY
FOOD SUPPLIES & CONSUMER WELFARE DEPARTMENT
KHANDAGIRI, ODISHA, BHUBANESWAR, PIN-751030
TENDER NOTICE (No.2/2020-21)

Sealed tenders through two bid systems are invited from the Manufacturer of Legal Metrology or his authorised Dealer having work experience in fabrication under Central or State Government Departments for supply/ erection of four numbers of Proving Measures along with all its fittings/accessories to the Directorate of Legal Metrology, Odisha for construction of a calibration point for vehicle tanks in the Directorate Campus, Khandagiri, Bhubaneswar.

Details of the Job: The job includes the cost of manufacturing, loading, unloading, transporting, installation, insurance, painting, third party inspection, material test and taxes as applicable of the following provers along with accessories like wiring of inlet pipes from storage, drainage pipes etc. and dismantling of old provers.

- (a) 2000L proving measure- one
- (b) 1000L proving measure- one
- (c) 500L proving measure- one
- (d) 100L proving measure- one

1. The tender documents may be obtained by depositing Rs.100/- (Rupees One hundred only) between 11AM to 5PM on each working days from the under signed in the address given below or downloading from the website <https://dlm.pdsodisha.gov.in> or www.foododisha.in and should be submitted duly signed in each page with the tender documents with seal in token of having read, understood and accepted the terms and conditions in the contract given below. The tender should also be submitted in prescribed format along with a A/C payee Demand Draft of Rs.100/- (one hundred rupees) in favour of "Controller Legal Metrology, Odisha" payable at Bhubaneswar towards cost of tender papers. The authorities shall not be responsible for postal or any other delay.
2. The earnest money to be deposited through A/C Payee DD with bid papers in favour of "Controller Legal Metrology, Odisha, Bhubaneswar" payable at Bhubaneswar. DD shall be returned in original with your without reverse endorsement as required for the refund. EMD of the successful bidder shall be retained till the supplied materials are delivered and successfully installed as ordered or adjusted against performance security. After that, it shall be returned in the same manner as in case of unsuccessful bidder.
3. Bid submitted other than the manner prescribed in the tender document shall be rejected.
4. The tender holding authority has right to accept or reject the tender without assigning reason thereof. The bidder should drop the sealed tender packet in the "Tender Box" available in the office of the undersigned by the stipulated date and time at his own risk and responsibility.
5. (a) Date of sale of tender documents with effect from **05.02.2021.**
(b) Last date of sale of tender documents **15.02.2021 before 4PM.**
(c) Last date of submission of bid papers (technical as well as financial)-**15.02.2021, 5PM.**
(d) Technical and financial bid opening- **17.02.2021 at 1PM.**
6. Bidders are required to depute their representative to remain present during opening of tender/ technical bid as per dates mentioned above.
7. The tenders received after the stipulated date shall not be taken into consideration and liable for rejection.
8. The tender calling authority has the right to cancel or alter quantity of any of above item without assigning any reason thereof.
9. The bidder must have valid licence of Manufacturer in Weights & Measures of the concerned state.
10. The term of completion of the work 2 months from the date of work order.
11. All the information as called for in the tender documents should be submitted truly, clearly, legibly, transparently, unambiguously and without the use of abbreviation. It shall be submitted in English.
12. All the crucial figures like rates and amount should be quoted in Indian Rupees in figures followed by words in a bracket. There shall be no overwriting in the tender documents and other paper submitted.

All the addition, alterations, deletions and cuttings should be initialled with rubber stamp (or seal) by the same person who signs the tender documents.

13. The tenders not submitted in prescribed format or in the prescribed manner shall be rejected at the risk and responsibility of the bidder.
14. Submission of more than one competitive bid by the same firm in response to the tender call notice is prohibited. All such bids except one will be cancelled with the discretion of the authority calling the bids.
15. The technical bid and financial bid identified as technical/ financial should be submitted in closed covers separately. Both the covers and other papers/documents of the bidder should be put inside a bigger sealed cover. All the sealed covers shall have bold written with the name of the supplier/ bidder, tender called notice number and the last date for submission.
16. The tenders or the bids can be sent by Registered post or courier as well, however the authority shall not be responsible for the postal and other delay in receipt of bids.
17. No firm/ company without valid GST registration number and PAN shall be eligible for submitting bids. Firms blacklisted shall also not be eligible to participate in the bid.
18. If the last date for submission of tender/bid turns out to be a holiday, it will automatically be extended to next working day.
19. A bid submitted can't be withdrawn.
20. The sealed tenders and technical bids shall be opened by the technical committee.
21. The documents like EMD, Manufacturing licence, GST registration number etc. shall be verified to ensure that, the bidders have been found to have fulfilled all the prescribed criteria and condition of this tender document other than technical specifications of the product. The decision of the technical committee in this respect shall be final and binding.
22. Financial bid shall be opened only in those cases that have fulfilled the prescribed technical specification. On delivery, the supplies or products shall be inspected to verify the quantity to see whether those are in accordance with the technical specifications (or quality requirements) for which the order was placed. If it turns out to be otherwise the acceptance of delivery shall be refused at the risk and responsibility of the supplier. Further, the articles found damaged shall not be counted as accepted until repaired or replaced to the satisfaction of the authority.
23. All the transit risks shall be the responsibility of the supplier.
24. Failure to supply the order in full within the stipulated period or supply of substandard goods may lead to forfeiture of EMD and blacklisting of the suppliers. If at all the delivery is allowed to be accepted after the due date, Liquidated Damages (LD) @ 0.5% of the total amount of order (excluding taxes) per week or part thereof shall be charged from the bidder, however, that the L.D. shall not exceed 5% of the amount of order.
25. The supplier shall give a "Performance Warranty" for a minimum period of **one year** of the date of completion of installation. 5% of the amount of the order (excluding taxes) of the contract amount shall be deposited in shape of FDR/Irrevocable Bank Guarantee duly pledged in favour of Tender Calling Authority and shall be returned after the performance warranty period is over. The said amount may be forfeited partially or fully for failure to serve the purpose i.e. leakage, rust in the tanks. The Bank Guarantee should be enforceable and payable at Bhubaneswar. The Performance Security should remain valid for a period of 60 days beyond the date of completion of the obligation of the supplier including warranty obligations.
26. The supplier shall repair or replace at his own cost any component of the prover that may go out of order during warranty period.
27. **Payment:** 50% of the payment as per the bid amount will be made after arrival of the provers at Directorate campus. Rest amount excluding the performance security will be made after complete installation and calibration of the provers for certification.
28. All the disputes shall be subject to jurisdiction of Civil Court situated at Bhubaneswar.
29. Address:

Deputy Controller Legal Metrology, Odisha,
At/ Po- Khandagiri, Bhubaneswar, PIN-751030.

Seal and signature of the Bidder

Controller Legal Metrology, Odisha.

Technical Specification Details

Annexure-II

DIRECTORATE OF LEGAL METROLOGY
FOOD SUPPLIES & CONSUMER WELFARE DEPARTMENT
KHANDAGIRI, ODISHA, BHUBANESWAR, PIN-751030
TENDER NOTICE (No.2/2020-21)

- (a) Material Specification: All the Provers are to be fabricated from SS 304 with 4mm thickness sheet, manufactured from reputed industries like L&T, Zindal, Tata etc. with NABL approval.
- (b) Dimension: The dimensions of the Proving measures should be as per the **enclosed** sheet (4nos.).
- (c) Supplier should have a licence from Legal Metrology Department to manufacture the Provers.
- (d) All provers shall consist of two numbers of plug/ ball valve, freely adjustable plunger, a cover flange fitted on the top of the loading end and manhole cover and flange in case of 500L for cleaning purposes.
- (e) Inlet-outlet of Provers -3"/150" SORF except for 100L.
- (f) Standing cage around the 100L proving measure with ladder to ride the cage for easy calibration.
- (g) The job includes supply and erection at the calibration point with all fittings like piping, pumps, drain pipes and cost of replacement of old Provers including transportation.
- (h) All inlet water pipes from storage tank to Provers are to be made up of stainless steel.

Seal and signature of the Bidder

Controller, Legal Metrology
Odisha, Bhubaneswar

GENERAL NOTES

- 1 ALL DIMENSIONS IN MM, UNLESS OTHERWISE SHOWN
- 2 ALL NOZZLE SHALL BE WELD FPW WELD BY TIG AND REST BY SMAW.
- 3 ALL NOZZLE FLANGES SHALL BE AS PER ANSI B.16.5.
- 4 PROVER TANK DIMENSION & MATERIAL OF CONSTRUCTION AS PER IS 2941-1988.
- 5 THICKNESS OF PROVER TANK 2 mm MINIMUM.
- 6 TOLERANCE ON PROVER TANK DIMENSIONS 20%.
- 7 CORROSION ALLOWANCE NIL.
- 8 THE PERMISSIBLE ERROR IN THE CAPACITY OF THE MEASURE BE ±0.1% OF THE CAPACITY OF THE MEASURE.
- 9 WORKING PRESSURE : ATMOSPHERIC.
- 10 HYDROTEST PRESSURE : FILL OF WATER.
- 11 ALL INTERNAL AND EXTERNAL JOINTS SHALL BE SMOOTH & FREE FROM SCALE.

DESIGN DATA

DESIGN PRESSURE KG/CM ²	ATMOSPHERIC
HYD. TEST PRESSURE KG/CM ²	FILL OF WATER
WORKING TEMPERATURE	AMBIENT
DESIGN TEMPERATURE	AMBIENT
DESIGN CODE	IS 2941-1988

No.	DESCRIPTION	SIZE/SPCC	MATL.	QTY
11	INLET	1" x 1/2" NPT	SS 304	1
10	MOUNTING PLATE	5 mm THK PLATE	SS 304	4
9	Baffle PLATE	5 mm THK PLATE	SS 304	1
8	DRAIN VALVE	1" NPT VALVE	CS 125 #	1
7	ADJUSTING DEVICE	AS PER DRAWING	SS 304	1
6	LEVEL GAUGE	AS PER DRAWING	SS 304	1
5	LEGS	ICMC 75	IS 2002 GR.B	3
4	BOTTOM CONE	540.00 X 115.00 X 80 LONG X 2.0 THK	SS 304	1
3	TOP SHELL	125.00 X 400 LENGTH X 2.0 THK	SS 304	1
2	TOP CONE	540.00 X 125.00 X 78 LONG X 2.0 THK	SS 304	1
1	SHELL	540.00 X 368 LENGTH X 2.0 THK	SS 304	1

MAJOR MATERIAL OF CONSTRUCTION

CUSTOMER	Legal Metrology Department, Odisha
END USER	Calibration Facility, Bhubaneswar
PROJECT	

Legal Metrology Department
Odisha

SCALE:	N.T.S.	DRG. NO.:	
--------	--------	-----------	--

EQUIPMENT NAME:	100 LTRS. PROVER TANK	REV.	1
-----------------	-----------------------	------	---

PLAN

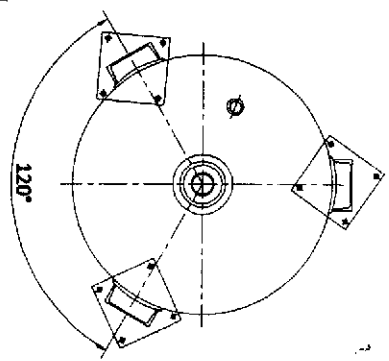

ELEVATION

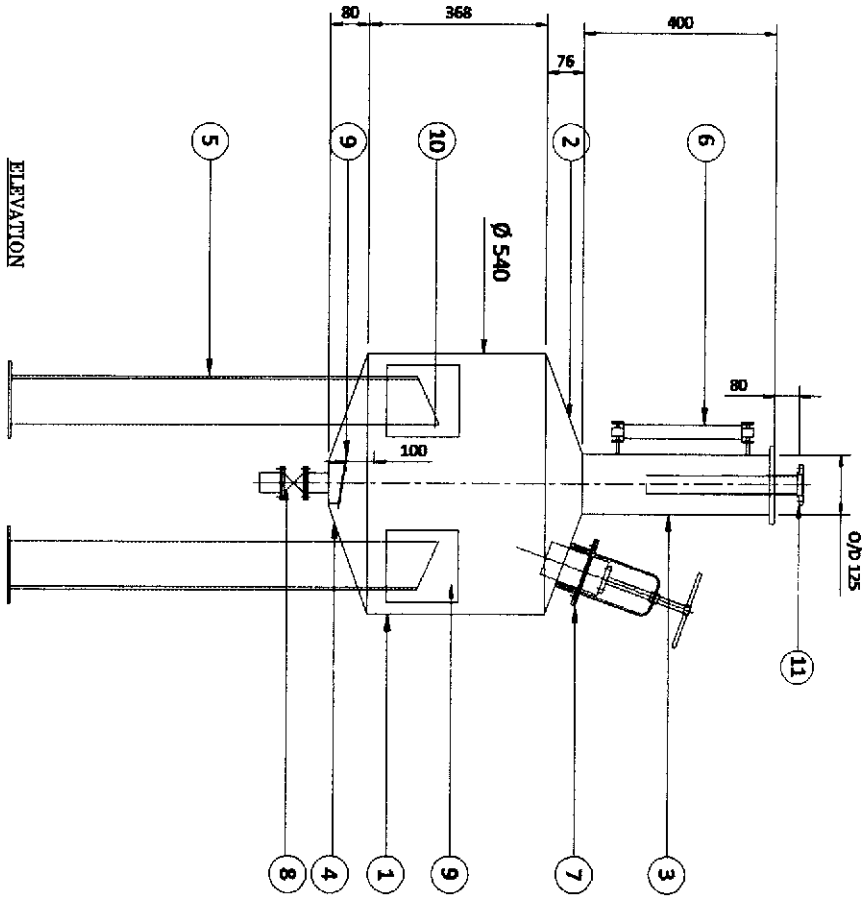

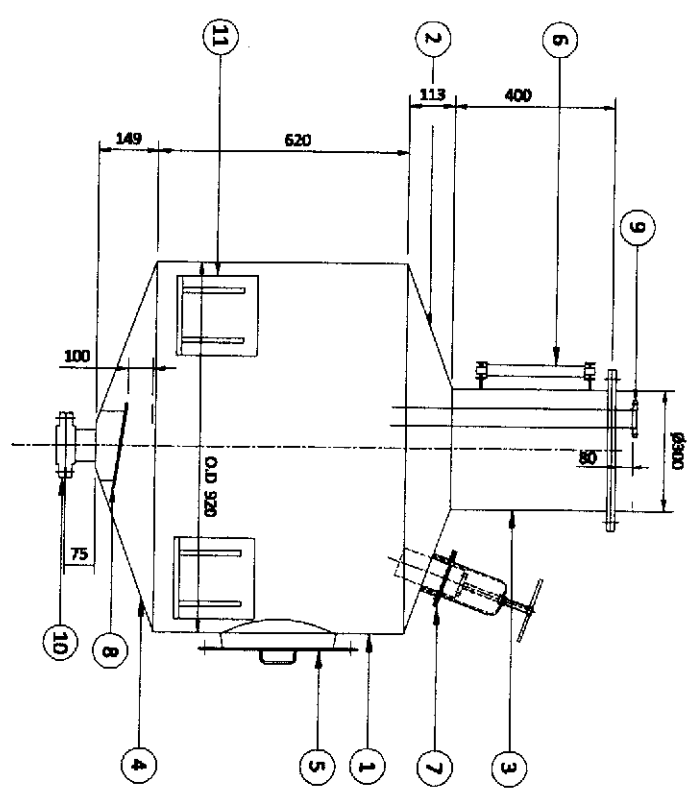
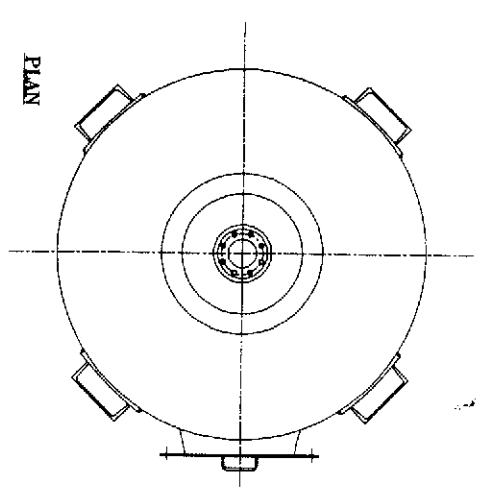

GENERAL NOTES

1. ALL DIMENSIONS IN MM. UNLESS OTHERWISE SHOWN.
2. ALL NOZZLE SHALL BE WELD P/W WELD BY TIG AND REST BY SMAW.
3. ALL NOZZLE FLANGES SHALL BE AS PER ANSI B.16.5.
4. PROVER TANK DIMENSION & MATERIAL OF CONSTRUCTION AS PER IS 2941-1963.
5. THICKNESS OF PROVER TANK 4 MM MINIMUM.
6. TOLERANCE ON PROVER TANK DIMENSIONS ±5%.
7. CORROSION ALLOWANCE NIL.
8. THE PERMISSIBLE ERROR IN THE CAPACITY OF THE MEASURE BE ±0.1% OF THE CAPACITY OF THE MEASURE.
9. WORKING PRESSURE : ATMOSPHERIC.
10. HYDROTEST PRESSURE : FILL OF WATER.
11. ALL INTERNAL AND EXTERNAL JOINTS SHALL BE SMOOTH & FREE FROM SCALE.

DESIGN DATA

DESIGN PRESSURE KG/CM ²	ATMOSPHERIC
HYD. TEST PRESSURE KG/CM ²	FILL OF WATER
WORKING TEMPERATURE	AMBIENT
DESIGN TEMPERATURE	AMBIENT
DESIGN CODE	IS: 2941-1963

Sl	NO.	DESCRIPTION	MATL.	QTY
12	1	NOZZLING PLATE	SS 304	4
11	2	OUTLET	SS 304	2
10	3	3" X 1500 SORE	SS 304	1
9	4	INLET	SS 304	1
8	5	BAFFLE PLATE	SS 304	1
7	6	ADJUSTING DEVICE	AS PER DRAWINGS	1
6	7	LEVEL GAUGE	SS 304	1
5	8	MANHOLE FLANGE & COVER	SS 304	1
4	9	BOTTOM CONE	SS 304	1
3	10	TOP SHELL	SS 304	1
2	11	TOP CONE	SS 304	1
1	12	SHELL	SS 304	1

MAJOR MATERIAL OF CONSTRUCTION

CUSTOMER	Legal Metrology Department, Odisha
END USER	Calibration Facility, Bhubaneswar
P O No	

Legal Metrology Department Odisha	
SCALE	DWG. NO.:
N.T.S.	

EQUIPMENT NAME	700 LITRS. PROVER TANK
REV.	1

ELEVATION

PLAN

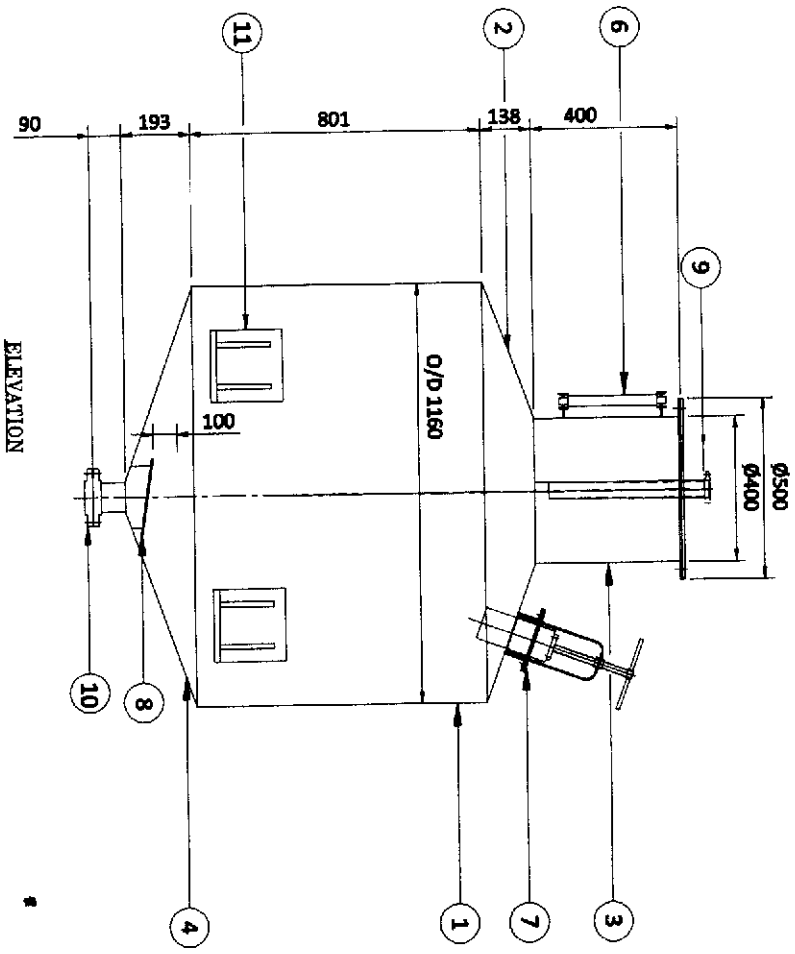
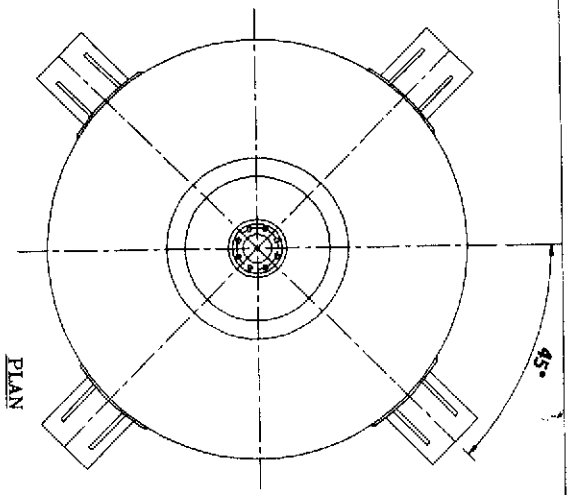

GENERAL NOTES

- 1 ALL DIMENSIONS IN MM UNLESS OTHERWISE SHOWN.
- 2 ALL NOZZLE SHALL BE WELDED FPM WELD BY TIG AND REST BY SMAW.
- 3 ALL NOZZLE FLANGES SHALL BE AS PER ANSI B.16.5.
- 4 PROVER TANK DIMENSION & MATERIAL OF CONSTRUCTION AS PER IS 2941-1983.
- 5 THICKNESS OF PROVER TANK 4 MM MINIMUM.
- 6 TOLERANCE ON PROVER TANK DIMENSIONS 5%.
- 7 CORROSION ALLOWANCE NIL.
- 8 THE PERMISSIBLE ERROR IN THE CAPACITY OF THE MEASURE BE 0.1% OF THE CAPACITY OF THE MEASURE.
- 9 WORKING PRESSURE : ATMOSPHERIC
- 10 HYDROTEST PRESSURE : FULL OF WATER
- 11 ALL INTERNAL AND EXTERNAL JOINTS SHALL BE SMOOTH & FREE FROM SCALE.

DESIGN DATA

DESIGN PRESSURE KG/CM ²	ATMOSPHERIC
HYD. TEST PRESSURE KG/CM ²	FULL OF WATER
WORKING TEMPERATURE	AMBIENT
DESIGN TEMPERATURE	AMBIENT
DESIGN CODE	IS-2941-1983

NO.	DESCRIPTION	SIZE/SPEC.	MATERIAL	QTY.
11	MOUNTING PLATE	200 * 250 X 4 MM THK.	SS 304	4
10	OUTLET	3" * 1500 SOF	SS 304	1
9	INLET	3" * 1500 SOF	SS 304	1
8	BARREL PLATE	3MM THK PLATE	SS 304	1
7	ADJUSTING DVMC	AS PER DRAWING	SS 304	1
6	LEVEL GAUGE	AS PER DRAWING	SS 304	1
5	BOTTOM CONE	1160 OD X 116 ID X 180 LONG X 4 THK	SS 304	1
4	TOP SHELL	400 OD X 400 LENGTH X 4 THK	SS 304	1
2	TOP CONE	1160 OD X 400 ID X 180 LONG X 4 THK	SS 304	1
1	SHELL	1160 OD X 800 LENGTH X 4 THK	SS 304	1

MAJOR MATERIAL OF CONSTRUCTION

CUSTOMER	Legal Metrology Department, Odisha
END USER	Calibration Facility, Bhubaneswar
P.O.NO.:-	

SCALE:	DWG. NO.:	
M.T.S.		
EQUIPMENT NAME:		

1000 LTRS. PROVER TANK

REV.	0
------	---

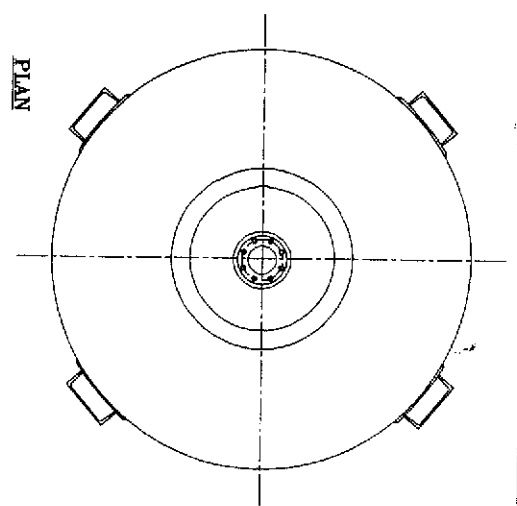

PLAN

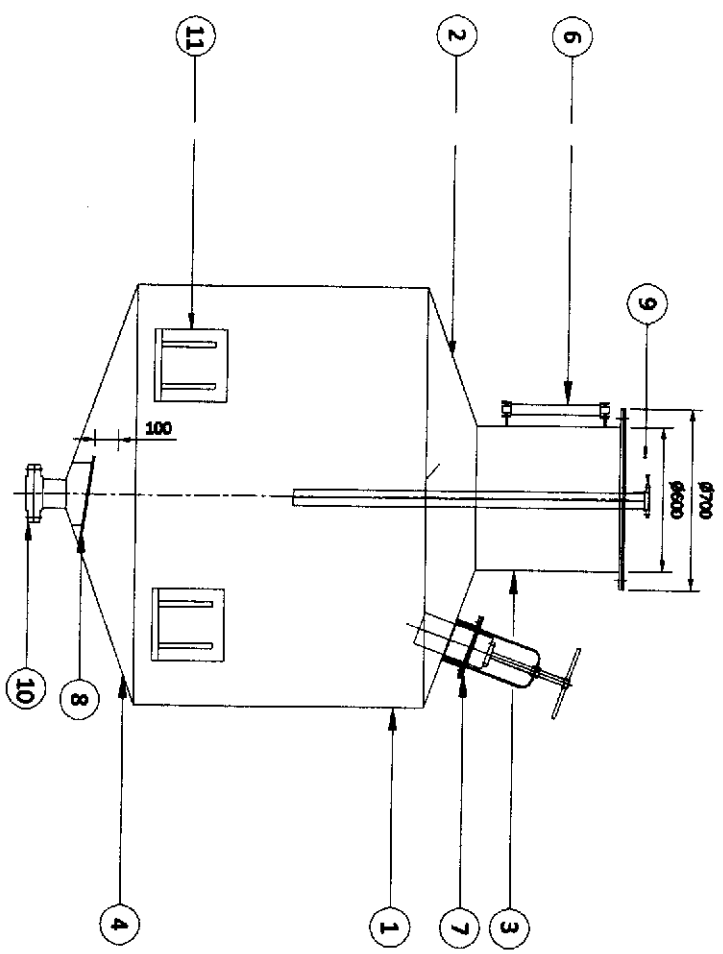

ELEVATION

GENERAL NOTES

- 1 ALL DIMENSIONS IN MM, UNLESS OTHERWISE SHOWN.
- 2 ALL NOZZLE SHALL BE WELD F/W WELD BY TIG AND REST BY SMAW.
- 3 ALL NOZZLE FLANGES SHALL BE AS PER ANSI B.16.5.
- 4 PROVER TANK DIMENSION & MATERIAL OF CONSTRUCTION AS PER IS 2941-1983.
- 5 THICKNESS OF PROVER TANK 4MM MINIMUM.
- 6 TOLERANCE ON PROVER TANK DIMENSIONS 25%.
- 7 CORROSION ALLOWANCE NIL.
- 8 THE PERMISSIBLE ERROR IN THE CAPACITY OF THE MEASURE BE 0.1% OF THE CAPACITY OF THE MEASURE.
- 9 WORKING PRESSURE : ATMOSPHERIC
- 10 HYDROTEST PRESSURE : FILL OF WATER
- 11 ALL INTERNAL AND EXTERNAL JOINTS SHALL BE SMOOTH & FREE FROM SCALE.

DESIGN DATA

DESIGN PRESSURE KG/CM ²	ATMOSPHERIC
HYD. TEST PRESSURE KG/CM ²	FULL OF WATER
WORKING TEMPERATURE	AMBIENT
DESIGN TEMPERATURE	AMBIENT
DESIGN CODE	IS 2941-1983

No.	DESCRIPTION	SIZE/SPEC.	MATL.	QTY
11	Mounting Plate	200 x 250 x 4MM THK	S.S 304	4
10	Outlet	5" x 1500 SCRF	S.S 304	1
9	Inlet	3" x 1500 SCRF	S.S 304	1
8	Handle Plate	4MM THK PLATE	S.S 304	1
7	Adjusting Device	AS PER DRAWING	S.S 304	1
6	Level Gauge	AS PER DRAWING	S.S 304	1
5	Bottom Cone	1400 OD X 90 ID X 292 LONG X 4 THK	S.S 304	1
4	Top Shell	400 OD X 400 LENGTH X 4 THK	S.S 304	1
3	Top Cone	1400 OD X 400 ID X 150 LONG X 4 THK	S.S 304	1
2	Shell	1400 OD X 902 LENGTH X 4 THK	MS	1
1	Shell	1400 OD X 902 LENGTH X 4 THK	MS	1

MAJOR MATERIAL OF CONSTRUCTION

CUSTOMER	Legal Metrology Department, Odisha
END USER	Calibration Facility, Bhubaneswar
P.O. NO. :-	

SCALE:	N.T.S.	DWG. NO.:	
EQUIPMENT NAME:	2000 LITRS. PROVER TANK		
REV.:	0		

GENERAL BID FORM
DIRECTORATE OF LEGAL METROLOGY
FOOD SUPPLIES & CONSUMER WELFARE DEPARTMENT
KHANDAGIRI, ODISHA, BHUBANESWAR, PIN-751030
TENDER NOTICE (No.2/2020-21)

1. Name & Full Address:

Fax No.,

Telephone No.,

E-Mail,

2. Legal status of the firm:

(a) Manufacturing or Dealership Licence of Weights & Measures.:

(b) GST Registration Certificate

(c) PAN

3. Whether you are the original equipment manufacturer (OEM)/ Dealer:

4. Give the location and Address of your Factory:

5. In case the applicant is not an OEM, Kindly confirm by writing 'yes' or 'no' only that you have been an authorized agent by the respective OEMs or as an authorised Dealer:

6. Have you enclosed the EMD? If yes, mention the amount and its identifying details.

7. Have you enclosed all the documents and papers called for in this tender document? Kindly enclose a list (use a separate sheet of paper):

8. If the answer to (10) above is 'No' which is the documents/document have not been enclosed. (Kindly enclose a list of such documents/papers). Use a separate sheet of paper if necessary:

9. Do you have a post sales servicing, centre in Odisha? If yes, give its name, full address, Fax and Telephone numbers:

Certified that, the information submitted above is true to the best of my knowledge and belief.

Seal & Signature of the Bidder

Controller Legal Metrology, Odisha

DIRECTORATE OF LEGAL METROLOGY
FOOD SUPPLIES & CONSUMER WELFARE DEPARTMENT
KHANDAGIRI, ODISHA, BHUBANESWAR, PIN-751030
TENDER NOTICE (No.2/2020-21)

TECHNICAL BID

Sl.no.	Name of the items	Whether offered products fulfills the detailed technical specifications: kindly answer Yes or No.	Offered specifications and details of variations if any.
1	Licence of Weights & Measure		
2	Previous experience documents		
3	GST Licence		
4	PAN Card		
5	Proving Measures 2000L		
6	Proving Measures 1000L		
7	Proving Measures 500L		
8	Proving Measures 100L		
9	Other fittings		

Signature and seal of the Bidder.

DIRECTORATE OF LEGAL METROLOGY
FOOD SUPPLIES & CONSUMER WELFARE DEPARTMENT
KHANDAGIRI, ODISHA, BHUBANESWAR, PIN-751030
TENDER NOTICE (No.1/2020-21)

FINANCIAL BID

- NAME OF THE ITEMS: (Per unit price in Indian Rupees)
1. 2000L Prover-
 2. 1000L Prover-
 3. 500L Prover-
 4. 100L Prover-
 5. Other fittings (Ladder, Racks, inlet & outlet pipes)
 6. Transportation:
 7. Replacement charges of old Prover (3 nos.):
 8. Installation and Calibration charges:
 9. Other cost if any.
 10. GST

Total Cost of the Bid

(Rupees

Rs.

only

Signature and seal of the Bidder.